



CERN-ACC-2015-0104

Karsten.Kahle@cern.ch

The design and performance of Static Var Compensators for particle accelerators

Karsten Kahle, Francisco R. Blázquez, Charles-Mathieu Genton
CERN, Geneva, Switzerland,

Keywords: «Static Var Compensator (SVC)», «reactive power compensation», «power quality», «particle accelerator», «harmonic filtering».

Abstract

Particle accelerators, and in particular synchrotrons, represent large cycling non-linear loads connected to the electrical distribution network. This paper discusses the typical design and performance of Static Var Compensators (SVCs) to obtain the excellent power quality levels required for particle accelerator operation.

Presented at: EPE 2015, 7-10 September 2015, Geneva, Switzerland

Geneva, Switzerland
October, 2015

The design and performance of Static Var Compensators for particle accelerators

Karsten Kahle, Francisco R. Blázquez, Charles-Mathieu Genton
CERN – European Organization for Nuclear Research

1211 Geneva 23, Switzerland

karsten.kahle@cern.ch, francisco.rafael.blanquez.delgado@cern.ch,
charles-mathieu.genton@cern.ch

Keywords

«Static Var Compensator (SVC)», «reactive power compensation», «power quality», «particle accelerator», «harmonic filtering».

Abstract

Particle accelerators, and in particular synchrotrons, represent large cycling non-linear loads connected to the electrical distribution network. This paper discusses the typical design and performance of Static Var Compensators (SVCs) to obtain the excellent power quality levels required for particle accelerator operation.

1. Introduction

For the electrical distribution network, particle accelerators represent large cycling non-linear electric loads with a variable power factor. The twelve-pulse thyristor power converters for the main dipole and quadrupole magnets represent the major part of the load. The large amplitudes, and the steep gradients of the power cycles require rapid reactive power control, for voltage stabilisation and compensation of varying reactive power. As an additional aspect, strong harmonic filtering is required to eliminate the harmonics generated by the thyristor power converters. The application of Static Var Compensator (SVC) technology perfectly covers these three functions [1]-[3].

An SVC typically consists of a combination of harmonic filters for the generation of (capacitive) reactive power and for harmonic filtering, as well as thyristor controlled reactors (TCR) to allow for the control of variable reactive power output. This paper discusses the design and performance of Static Var Compensators with harmonic filters and TCR, and also gives specific guidelines for the design of SVCs for particle accelerators. The technical examples and diagrams given in this paper are based on recent engineering studies made for the SVC MEQ59, for CERN's Proton Synchrotron Booster (PSB) accelerator. This SVC project is currently in progress.

2. Brief overview of existing technologies

Several different technologies exist for the decoupling from the electrical network of large cycling power converter loads. All of them are controlling the output of reactive, and in some cases also of active power:

- Motor-generator sets: A motor is driving a large synchronous generator which supplies the cycling power converter load. An additional fly-wheel may be used to increase the stored kinetic energy required for the generation of the power cycles. Due to the kinetic energy stored in the rotation of the motor-generator set, the power drawn from the electrical network by the motor follows the accelerator cycles with relatively small power variations. In order to mitigate the risks of major machine failure, combinations of several smaller motor-generator sets could be used instead of one large system.
- STATCOM without energy storage: Covers the same functions as an SVC, by controlling its variable output of reactive power. Harmonic filtering is achieved by a combination of active and passive filtering. For very fast cycling loads, a STATCOM has a superior performance compared to an SVC, in terms of voltage stabilization [2].

- STATCOM with energy storage: Controls a variable output of active and reactive power, and hence completely decouples the cycling load from the electrical network. This technology is particularly suitable to connect large cycling power converter loads to relatively weak electrical networks. Such a STATCOM could potentially also be used to eliminate voltage variations of electrical networks supplying sensitive loads. Harmonic filtering is achieved by a combination of active and passive filtering [4].
- Integration of DC storage capacitor banks into the power converters: This topology combines an Active Front End (AFE) with one or several DC/DC converters, with integrated DC capacitor banks storing the energy for the next load cycle. In such a system, the stored energy is swinging back and forth between the accelerator magnets and the DC capacitor banks. The AFE operates at unity power factor and almost constant power, and only provides the losses occurring in the power converters and in the accelerator magnets [5].
- Thyristor switched capacitors: The step-wise switching of capacitor banks allows approximate reactive power compensation [2]; however the step changes could potentially disturb the particle beam.
- Static Var Compensator (SVC): Controls a variable output of reactive power for Mvar compensation and AC network voltage control. The harmonic filtering is achieved by passive filters [1]-[3].

For the reactive power compensation of the existing cycling 12-pulse power converters for the PSB accelerator, the SVC technology was chosen for its modular and reliable design, good performance for AC voltage control and harmonic filtering, and significantly lower price compared to STATCOM technology.

3. Determination of required SVC ratings

The SVC should be installed on the medium voltage level of the electrical network. The best performance is achieved by connecting the SVC at the same medium voltage substation as the cycling power converter load, typically directly downstream of the feeding HV/MV transformer. As an example, figure 1 shows the electrical network for CERN's Proton Synchrotron Booster (PSB) accelerator.

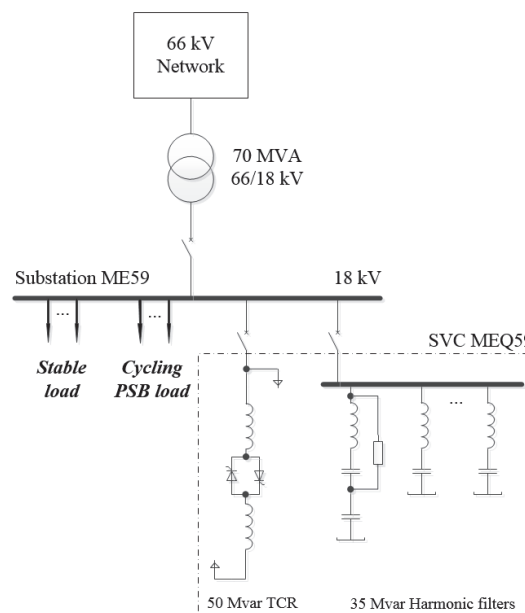

Fig. 1: Electrical network for CERN's PSB accelerator

An SVC cannot assure perfect voltage stabilization and perfect reactive power compensation at the same time. For most particle accelerators, the requirement for highest power quality precedes the need for

perfect reactive power compensation. For optimum voltage stabilization, the variable reactive power output of the SVC hence needs to compensate not only the cycling reactive power of the load, but also correct the voltage variations caused by the cycling active power [6]:

$$Q_{SVC} = Q_{load} + \frac{P_{load}^2}{2S_{cc}} + kP_{load} \quad (1)$$

$$\text{With } k = \frac{R}{X} \text{ of the supplying network} \quad (2)$$

Equation (1) defines the required minimum rating of the SVC. Additional Mvars might be required if the SVC also needs to correct small additional voltage disturbances, e.g. step changes due to tap changer operation.

In most cases, the Mvar ratings of the harmonic filters and of the TCR are identical; however, for certain applications a slightly increased TCR might be an interesting option.

4. Harmonic filter design and harmonic performance

4.1 Method for harmonic calculations

The harmonic contributions from the power converter load, and also from the TCR, are rapidly cycling. Conventional power quality definitions based on IEC standards might not be applicable here, because the time window for the FFT calculation of the harmonic spectrum is too large. At CERN, the harmonic calculations and the harmonic filter design for SVCs are typically based on that particular time window of 100 ms during an entire load cycle, where the harmonic distortion is the maximum. For rapidly cycling systems, it is therefore a snapshot of the worst-case situation in terms of harmonic voltage and current distortion.

During particle accelerator operation, most of the thyristor power converters of the load operate at the same operating point, and therefore their harmonic spectra need to be added arithmetically.

4.2 Required tuning frequencies of the harmonic filters

The total number of capacitors required for reactive power compensation are split into groups and then connected in series with air-core reactors to achieve the required harmonic tuning. The harmonic filters need to be designed taking into account the three major sources of harmonics:

- The 12-pulse thyristor power converter load (cycling harmonic current source with n=11, 13, 23 and 25),
- The TCR (cycling harmonic current source with n=5, 7, 11, 13, 17 and 19),
- The supplying external network (harmonic voltage source typically with n=5 and 7 in steady-state, and n=3 during transients). Particular attention is required to correctly estimate the harmonics coming from the supplying external network, as they greatly depend on the external network configuration and external load situation. The harmonic levels need to be taken into consideration for a highly loaded and also for a slightly loaded external network situation, as both cases result in different spectra of harmonic currents flowing from the external network into the harmonic filters of the SVC.

Based on the harmonic sources listed above, an SVC for particle accelerators should hence consist of harmonic filters for n = (2, 3,) 5, 7, 11, 13 and high-pass. A typical topology, based on studies for the SVC MEQ59 project for the PSB accelerator, is shown in Fig. 2:

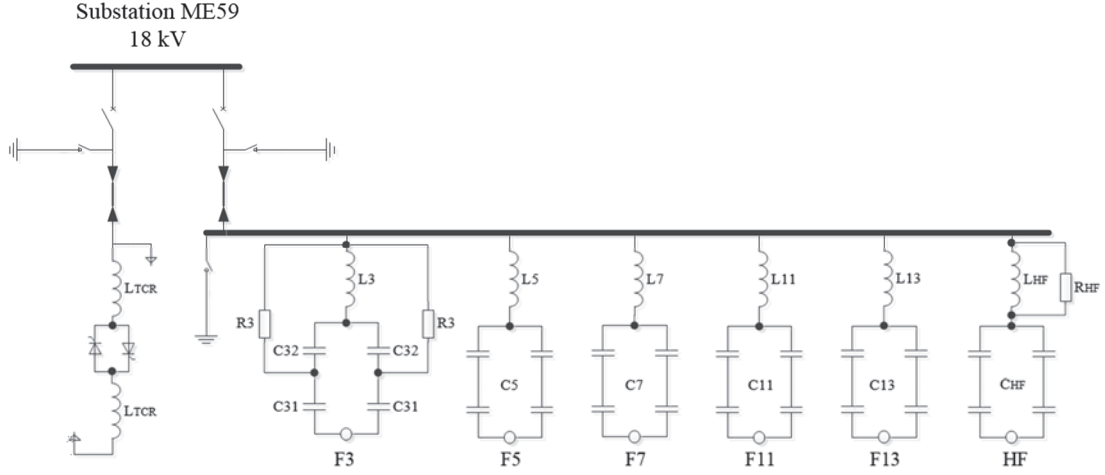

Fig. 2: Typical topology of an SVC for particle accelerator

4.3 The design of the third harmonic filter

The total quantity of the capacitors will create a parallel resonance with the inductances of the supplying network, at the following frequency [7]:

$$f_{res} = f_0 \sqrt{\frac{S_{cc}}{Q_{SVC}}} \quad (3)$$

For reliable SVC operation under all steady-state and transient conditions, the impedance of this resonance point needs to be controlled carefully. Being typically in the range of 100-250 Hz, it can hence lead to an amplification of second and third harmonics, and would therefore introduce instabilities during transient conditions. The installation of a damped third harmonic filter would prevent or limit the amplification of harmonics in this frequency range.

As a rule of thumb for the design of the third harmonic filter, the impedance at 100 Hz and at 150 Hz should be about the same with and without SVC. In our example SVC MEQ59, where the parallel resonance with the network is about 210 Hz, this objective is obtained by installing a third order harmonic filter; a second order harmonic filter is not required.

In order to reduce the fundamental frequency losses in the damping resistors of the third order harmonic filter, it is recommended to design them as so-called C-type filters. In this configuration, the fundamental current does not flow through the damping resistor which still provides good damping at harmonic frequency. With reference to the F3 filter topology shown in figure 2, the C-type filter is designed as follows:

$$f_3 = \frac{1}{2\pi \sqrt{L_3 C_3}} \quad (4)$$

$$C_3 = (C_{31} + C_{32}) / (C_{31} C_{32}) \quad (5)$$

$$C_{31} = \frac{n^2}{n^2 - 1} C_3 \quad (6)$$

$$C_{32} = n^2 C_3 \quad (7)$$

4.4 The new standardized harmonic filter design used at CERN

Based on the discussion above, a standardized filter design was developed at CERN for the SVC MEQ59 project. The innovation of this new concept is the use of one single type of capacitors 20 μF / 8 kV for all harmonic filters, plus one additional type for the auxiliary capacitors of harmonic filter F3. The standardized filter design allows, for each harmonic filter, the choice between 4 Mvar and 6 Mvar ratings, just by increasing or decreasing the number of capacitor units installed, and using the same capacitor racks and the same filter reactors for both variants. Each filter reactor has 4 taps for fine tuning on one side, and one additional tap on the other side to choose between the rating of 4 Mvar and 6 Mvar, as shown in figure 3.

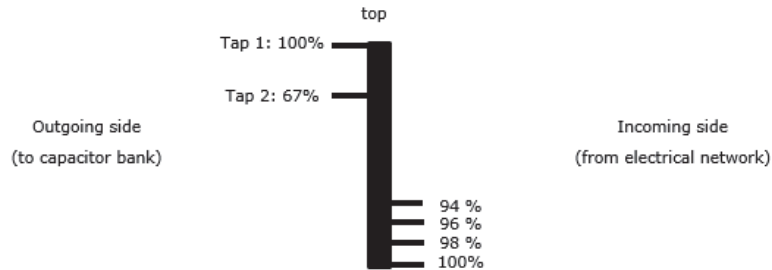

Fig. 3: Filter reactor design

As a result, this filter design can be used for SVCs of different ratings between 20 Mvar and 35 Mvar. Tables I and II show the main harmonic filter ratings, for the minimum and maximum SVC configurations. Intermediate variants with combinations of 4 Mvar and 6 Mvar filter ratings are also possible.

Table I: Minimal configuration for standardized SVC with 20 Mvar

Filter	F3	F5	F7	F11	F13	HF	Total Q
Q	-	4.2 Mvar	4.2 Mvar	4.1 Mvar	4.1 Mvar	4.1 Mvar	20.7 Mvar
L	-	10.13 mH	5.17 mH	2.09 mH	1.50 mH	0.78 mH	-
C	-	40 μF	40 μF	40 μF	40 μF	40 μF	-
R	-	-	-	-	-	22.5 Ω	-

Table II: Maximal configuration for standardized SVC with 35 Mvar

Filter	F3	F5	F7	F11	F13	HF	Total Q
Q	4.1 Mvar	6.4 Mvar	6.2 Mvar	6.2 Mvar	6.1 Mvar	6.1 Mvar	35.1 Mvar
L	31.70 mH	6.75 mH	3.45 mH	1.40 mH	1.00 mH	0.52 mH	-
C(main)	40 μF	60 μF	60 μF	60 μF	60 μF	60 μF	-
C(aux)	320 μF	-	-	-	-	-	-
R	300 Ω	-	-	-	-	15 Ω	-

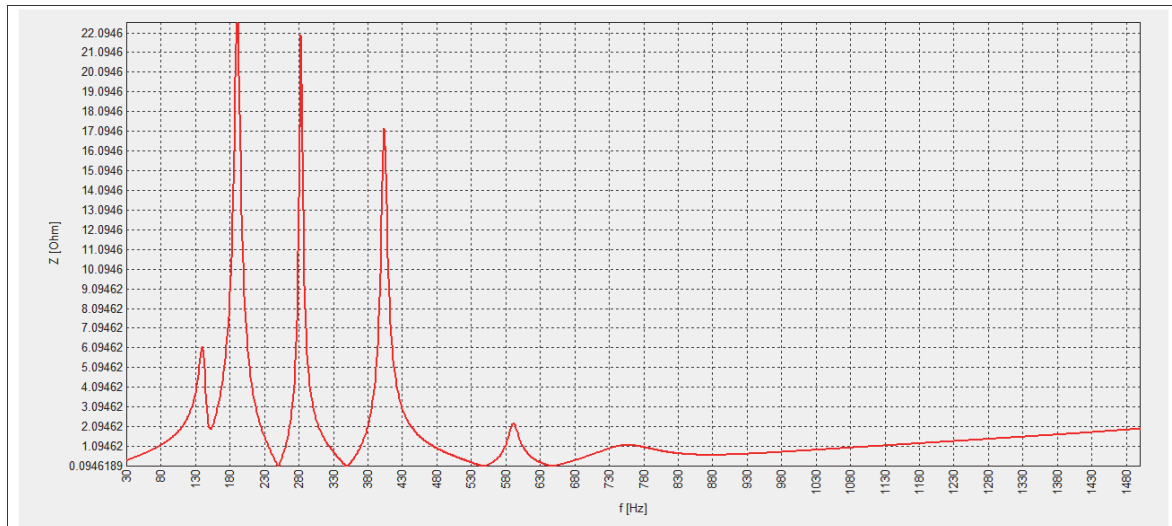

Fig. 4: Magnitude impedance diagram for the 35 Mvar harmonic filter topology (figure 2 and table II)

For SVCs at CERN, the harmonic filters F5, F7, F11 and F13 are not damped in many cases. The above filter design studies were done without damping for these filters, but the possibility for later addition of damping resistors is included into the design.

4.5 Fine tuning of the harmonic filters

Most SVCs for industrial applications such as steel plants or rolling mills have only three or four harmonic filters with non-adjustable filter resonance points. In comparison, SVCs for particle accelerators require a much better harmonic performance, aiming to reduce the Total Harmonic Voltage Distortion at the medium voltage substation below one percent. To achieve this objective, they typically have between five and eight harmonic filters and use adjustable air-core reactors for perfect tuning of filter resonance frequency (see figures 2 and 3).

Contrary to common practice in industry, where harmonic filters are often tuned slightly below their harmonic frequency, filters for particle accelerators require much better harmonic performance and should be tuned precisely to their rated harmonic frequency. However this design requires rigorous periodic preventive capacitor maintenance to avoid detuning due to tripped internal capacitor fuses. At CERN, an alarm is given in case of failure of one fuse, and the SVC is immediately tripped in case of failure of two or three fuses in one harmonic filter.

Finally, the chosen filter design must be verified for all possible worst-case combinations of capacitor and reactor tolerances, including their temperature drift between minimum and maximum ambient temperature.

4.6 Harmonic filter performance

The standardized harmonic filter design, in both variants 20 Mvar and 35 Mvar, would typically keep the 18 kV Total Harmonic Voltage Distortion (THD) at the SVC connection bus below 1%, during all phases of the load cycle (20 Mvar configuration THD=0.8%, 35 Mvar configuration THD=0.7%). Figure 5 shows the amplitude of the individual voltage harmonics at the 18 kV bus, for the 35 Mvar configuration.

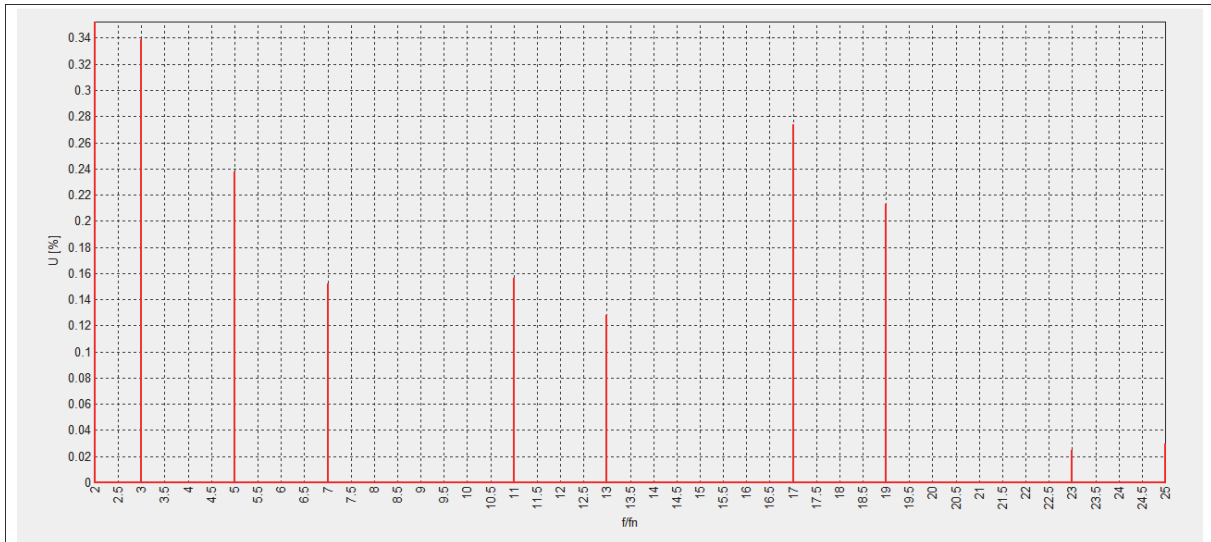

Fig. 5: Harmonic performance of the standardized harmonic filter design (35 Mvar configuration)

The above evaluation of harmonic performance shows that particular 100 ms time window during an entire load cycle, in which the Total Harmonic Voltage Distortion is the highest.

5. Thyristor controlled reactors (TCR)

The standardized harmonic filter design allows the modification of capacitive Mvar rating of the harmonic filters within a range between 20 Mvar and 35 Mvar. To adapt to this range, the TCR should be rated corresponding to the largest possible harmonic filter rating (e.g. at least 35 Mvar). At CERN, having standardized 3-phase TCR ratings of 25 Mvar, 50 Mvar and 150 Mvar, a TCR size of 50 Mvar was chosen for this project, corresponding to an inductance of 61.9 mH per phase.

6. TCR control strategy and voltage stabilization performance

The third principal function of an SVC is the stabilisation of the voltage of the AC network. SVCs for particle accelerators need to achieve exceptional performances also in this respect. For the performance evaluation of the SVC, the RMS value of the AC voltage at the MV substation is measured for each individual fundamental period of 20 ms. The SVC should aim to keep the variations of these individual RMS values within a tolerance band of $\pm 1\%$ around the nominal network voltage of 1 p.u., even during the fast cycling operation of the power converter load. The fast variation of SVC Mvar output power is done by controlling the firing angle of the Thyristor Controlled Reactors (TCR).

To achieve the required performance, a suitable TCR control system consists of an AC voltage regulation loop and a direct compensation of disturbance as shown in Figure 6. The direct disturbance compensation improves transient responses during cycling operation of the load. [8].

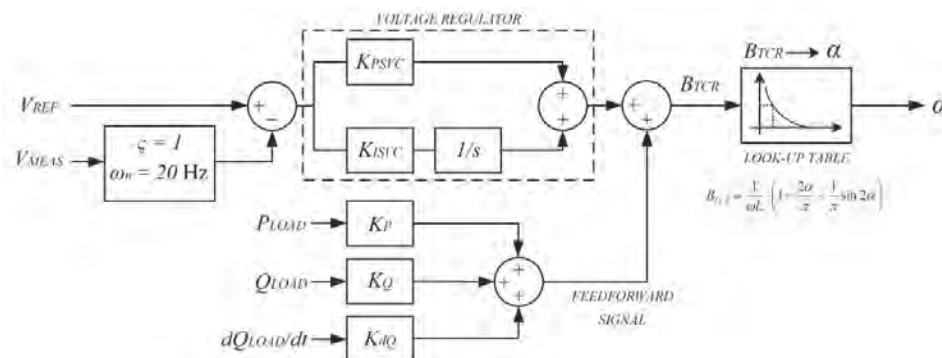

Fig. 6: Typical TCR control system for particle accelerators

If the TCR control system is based on a voltage regulation loop, it is often necessary to include the tap changer control of the feeding distribution network transformer into the TCR control system. In this way, the SVC should compensate voltage variations caused by the cycling load, and the transformer tap changer corrects slower voltage changes mainly coming from the supplying network.

Figure 7 shows the cycles of active power P and reactive power Q , of the SVC (figure 7a), of the feeding network (figure 7b) and of the power converter load (figure 7c). The simulations in Figure 7d indicate that the expected AC voltage variations will remain within a tolerance band of $\pm 0.3\%$ around the nominal voltage during operation with the very steep PSB converter cycles. For comparison, traditional industrial SVCs typically achieve voltage stabilisation within a few percent.

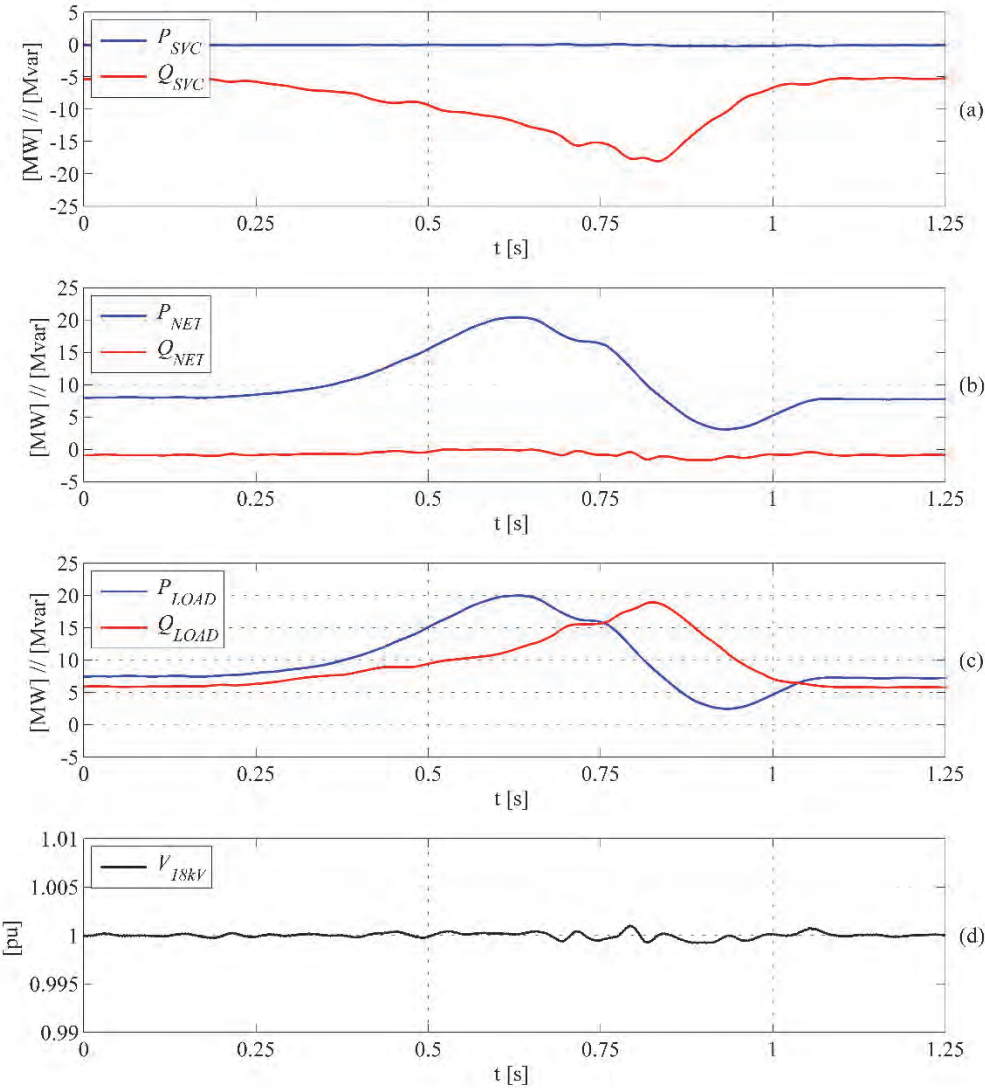

Fig. 7: Simulated cycles of active and reactive power, and the expected AC voltage response
 (a) Active and reactive power of SVC,
 (b) Active and reactive power taken from the network,
 (c) Active and reactive power of the cycling load,
 (d) AC voltage response at 18 kV substation ME59

To better understand the operation of the TCR during cycling operation, the SVC currents are shown in figure 8.

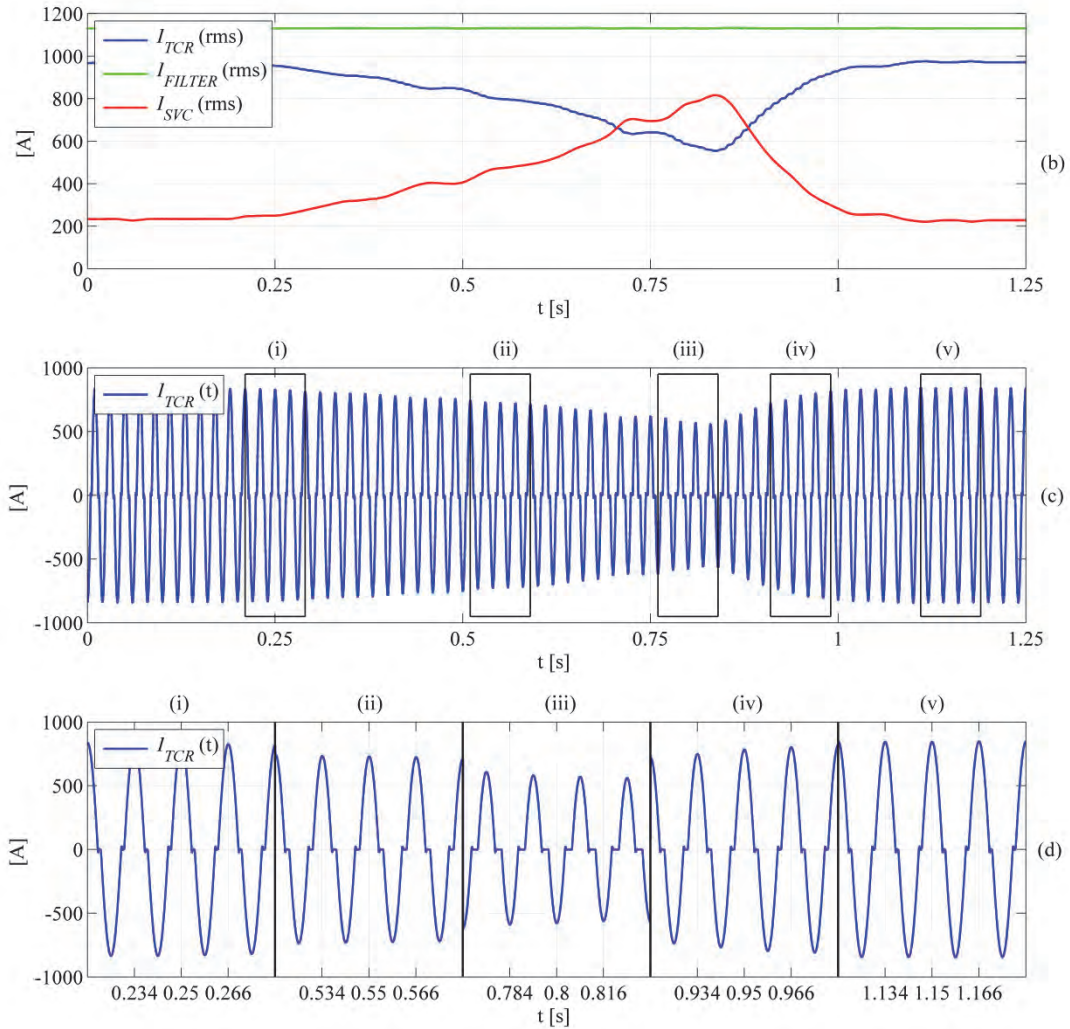

Fig. 8: Simulated SVC currents

- (a) Currents of harmonic filters, TCR and complete SVC,
- (b) Current in the TCR reactors (delta) during one entire load cycle,
- (c) Zoom of TCR current for different time windows during the cycle.

7. Conclusions

Typical synchrotron particle accelerators represent large cycling non-linear loads. This paper discusses in detail the use of Static Var Compensators for reactive power compensation, harmonic filtering and voltage control. The paper explains the specific design rules for SVCs for particle accelerator networks, and the typical SVC performance which can be achieved.

8. References

- [1] Kahle K., Pedersen J., Larsson T., de Oliveira M., The new 150 Mvar, 18 kV Static Var Compensator at CERN: Background, Design and Commissioning, CIRED Barcelona 2003, Session 2, paper No. 30
- [2] Hingorani N., Gyugyi L.: Understanding FACTS: Concepts and Technology of Flexible AC Transmission Systems, Wiley-IEEE Press, 2000, ISBN 978-0-7803-3455-7
- [3] Kahle K., Jovic D.: Static Var Compensator for CERN's Proton Synchrotron Particle Accelerator, Securing Critical Infrastructures, Grenoble 2004
- [4] Jovic, D., Kahle, K.: Compensation of Particle Accelerator Load Using Converter-controlled Pulse Compensator, Power Delivery, IEEE Transactions on, vol.21, no.2, pp.801, 808, April 2006
- [5] Farhni C., Rufer A., Bordry F., Burnet J.-P.: A Multilevel Power Converter with Integrated Storage for Particle Accelerators, Power Conversion Conference, Proc. PCC07, Nagoya, 2007 (IEEE, 2007), p. 1480.
- [6] Bayard O.: The Supply of the 148 MW Pulsed Power to the CERN SPS, IEEE Transactions on Nuclear Science, vol. NS-26, No.3, June 1979
- [7] IEEE Guide for the Application of Shunt Power Capacitors, IEEE Std 1036-2010 (Revision of IEEE Std 1036-1992), pp.1-88, 17 Jan. 2011
- [8] Jovic D., Kahle K.: Fast Feedforward SVC Controller for Improving Power Quality of Super Proton Synchrotron, Power Engineering Society General Meeting, 2006. IEEE, pp.6.